

## MAINTENANCE

Chrome faucets: Use only liquid cleansers or soapy water. Anti-lime or acidic cleaners such as scouring agents or abrasive sponges are to be avoided. Polish with a soft cloth.

Special finish faucets: Clean faucet with mild soap and water. Wipe the entire surface dry with a dry, clean, soft cloth after each use.

DO NOT USE CLEANERS WHICH CONTAIN ACIDS, HARSH CHEMICALS OR ABRASIVES.

## WARRANTY

Whitehaus Collection Point of Use Cold Water Faucets are warranted to be free of manufacture's defects on both material and workmanship for a period of 1 year.

Finishes: Polished Chrome, Brushed Nickel, Polished Nickel, and Oil Rubbed Bronze are warranted for 1 year.

Damage to a product caused by accident, misuse, abuse, or improper installation is not covered by the warranty. This includes improper care and cleaning or use of plumber's putty on our products. Silicon sealing compounds should only be used.

Proof of purchase (original sales receipt) must be provided with all warranty claims.

Whitehaus Collection is not responsible for label charges, installation, or other incidental or consequential costs. Liability under warranties expressed or implied is limited to replacement of defective goods only.

# WHITEHAUS COLLECTION

If you have any questions, please call us at:

Phone: 800-527-6690

Fax: 800-694-4837

General inquiries: [info@whitehauscollection.com](mailto:info@whitehauscollection.com)

For purchase orders, email us at:  
[orders@whitehauscollection.com](mailto:orders@whitehauscollection.com)

# WHITEHAUS COLLECTION

## POINT OF USE HOT/COLD WATER FAUCETS

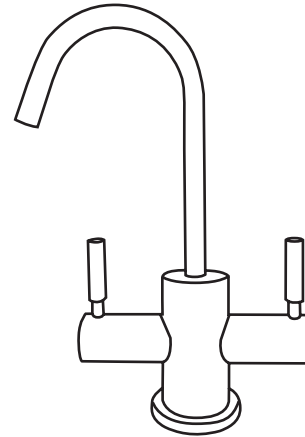

WHFH-HC1010

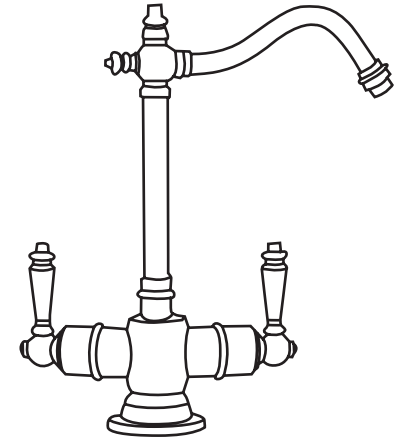

WHFH-HC1006

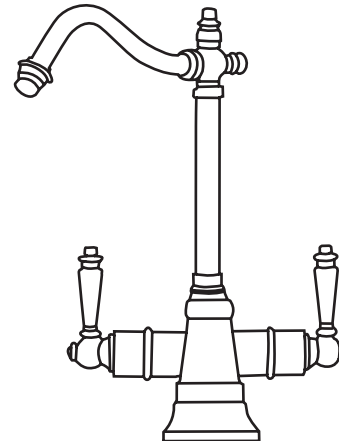

WHFH-HC2011

### INCLUDES:

INSTALLATION

BEFORE USE

DIMENSIONS

MAINTENANCE

WARRANTY

## INSTALLATION

Before installing a new faucet, properly flush out the pipework to remove any debris.

1. Place a small bead of silicone seal around the base of the faucet, and insert faucet through sink. Using mounting nut and washer, fasten faucet to sink. Do not overtighten.
2. Attach rubber line to mounting nipple using a nylon pinch clamp.
3. Attach cold water inlet line to cold water supply line.
4. Mount hot water tank to cabinet wall, and hang tank on bracket. DO NOT PLUG IN TANK.
5. Attach cold supply from faucet to corner inlet of tank.
6. Attach adapter to tank outlet and attach rubber hose to tank with the other pinch clamp.
7. Turn on water supply, and check for leaks. Open faucet handles to purge air from the system.
8. Hold hot handle open to fill the tank with water. Check for leaks. Now plug in tank, and turn knob on.
9. Allow tank to come to temperature - empty completely to rinse debris from system.

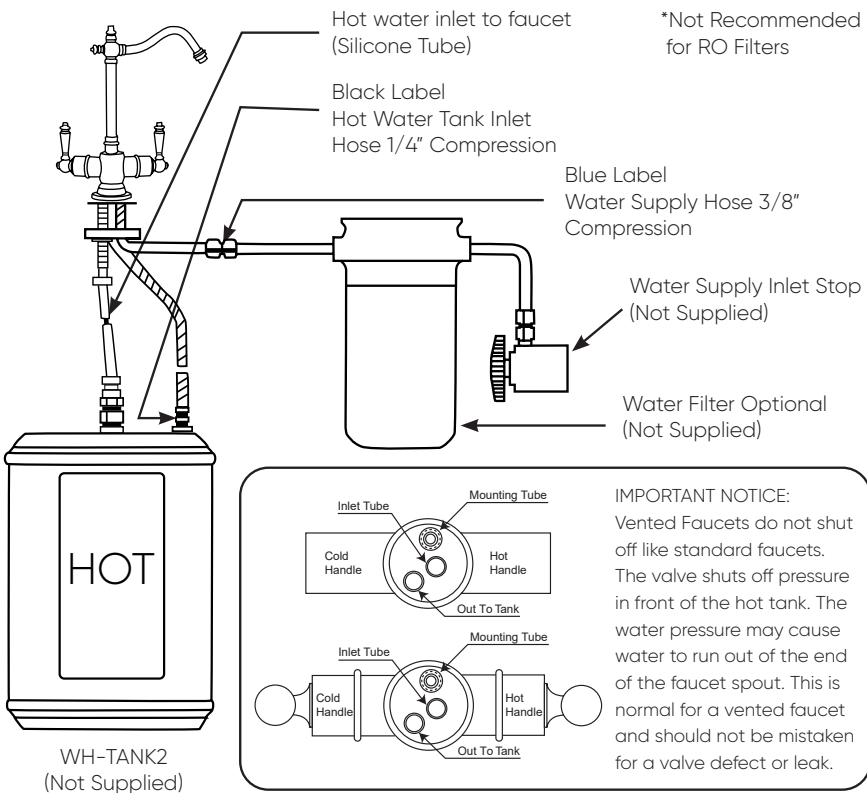

## BEFORE USE

After hot water has been dispensed during normal usage, the tank immediately starts the reheating process to bring the water in the tank back up to the temperature set on the thermostat. During that time, the water will expand and sometimes condense on the inside of the spout delivery tube and the unit may drip for a couple of minutes until the water in the tank reaches the set temperature. Normally, the heating process at startup or re-heating from a completely cold tank (two quarts) to the highest temperature setting takes no more than 20 minutes. This is normal for a vented faucet system. However, excessive pressure is not recommended for the hot tank installation, and recommended no more than 60 psi of incoming water pressure to provide the maximum performance from your system.

Water pressure: Inlet pressure above 60 psi may cause the water to "cavitate" inside the filtration system when water is dispensed. This creates tiny air bubbles and results in water that looks cloudy. If the water is left to stand and clears after a few minutes it verifies an overpressure condition in the filtration system - not a defect on the faucet, chiller, or hot tank. If the water remains cloudy, check the water source or filtration system. As always, never run hot water through a filter system.

\*WH-TANK2 tank is recommended for Whitehaus hot/hot and cold point of use faucets.

## DIMENSIONS

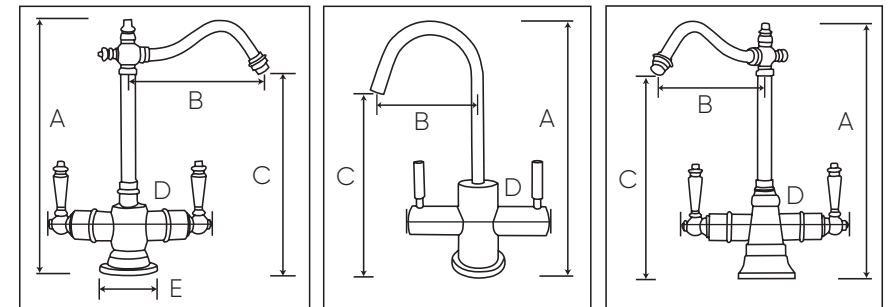

	WHFH-HC1006	WHFH-HC1010	WHFH-HC2011
A	9½"	9½"	9¾"
B	5¾"	4"	5¾"
C	7½"	6¾"	7½"
D	7"	5½"	6½"
E	2⅛"	2⅛"	2⅛"